

**Serie | 4, Built-in microwave oven, 60  
x 38 cm, Stainless steel  
BFL523MS0B**

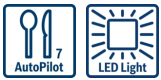

**Included accessories**

1 x Turntable

**The built-in microwave for the 38 cm niche:  
use it for thawing, heating and perfect  
preparation of foods.**

- **AutoPilot 7:** every dish is a perfect success thanks to 7 pre-set automatic programmes.
- **Red LED display control:** easy-to-use thanks to clear time display.
- **Pop-out controls:** for an easy to clean front.
- **LED lighting:** perfect illumination of foods with minimum energy consumption.

**Technical Data**

Type of micro-wave oven : MW only

Type of control : Electronic

Color / Material Front : Stainless steel

Cavity dimensions : 201.0 x 308.0 x 282.0 mm

Approval certificates : CE, E17D UKCA marking

Length of electrical supply cord : 130 cm

Net weight : 15.558 kg

Gross weight : 17.6 kg

EAN code : 4242005038862

Maximum micro-wave power : 800 W

Connection rating : 1270 W

Fuse protection : 10 A

Voltage : 230-240 V

Frequency : 50 Hz

Plug type : GB plug

Cavity dimensions : 201.0 x 308.0 x 282.0 mm



4 242005 038862

## **Serie | 4, Built-in microwave oven, 60 x 38 cm, Stainless steel BFL523MS0B**

**The built-in microwave for the 38 cm niche:  
use it for thawing, heating and perfect  
preparation of foods.**

---

### **Design**

- LED Display, red display
- Side opening door, left hinged
- 25.5 cm Glass turntable
- Cavity inner surface: stainless steel
- Electronic clock timer
- Rotary dial, Retractable control dials, Touch controls, round, Start button
- Touch key operation

### **Features**

- Automatic safety switch off  
Door contact switch
- AutoPilot, 7
- LED light
- Integral cooling fan
- Electronic open button

### **Programmes/functions**

- Maximum microwave power level: 800 W and the following options 180 W, 360 W, 600 W, 800 W, 90 W
- 4 defrost and 3 cooking programmes in microwave function
- 1 memory setting

### **Accessories**

- 1 x Turntable

### **Performance/technical information**

- Cavity volume: 20 l
- 130 cm Cable length
- Total connected load electric: 1.27 KW
- Nominal voltage: 230 - 240 V
- Appliance dimension (hxwxd): 382 mm x 594 mm x 317 mm
- Niche dimension (hxwxd): 362 mm - 365 mm x 560 mm - 568 mm x 300 mm
- For installation into a 60 cm wide wall unit, installation in tall housing
- Please refer to the dimensions provided in the installation manual

**Serie | 4, Built-in microwave oven, 60 x 38 cm, Stainless steel  
BFL523MS0B**

Microwave,  
corner installation

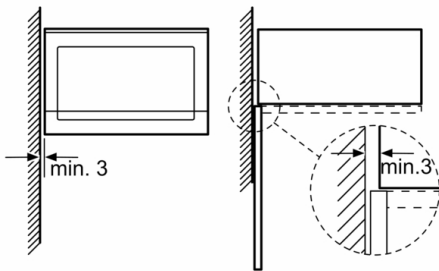

Measurements in mm

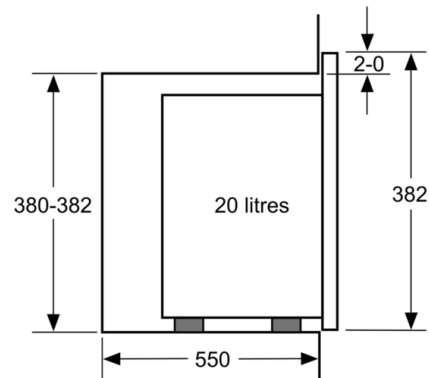

measurements in mm

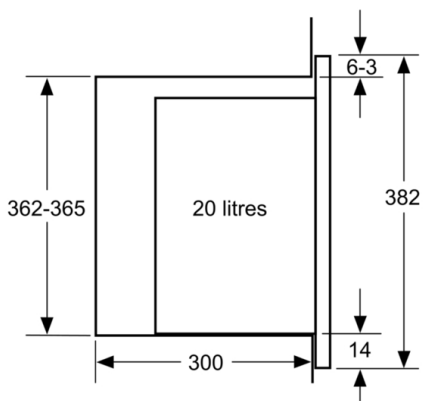

measurements in mm

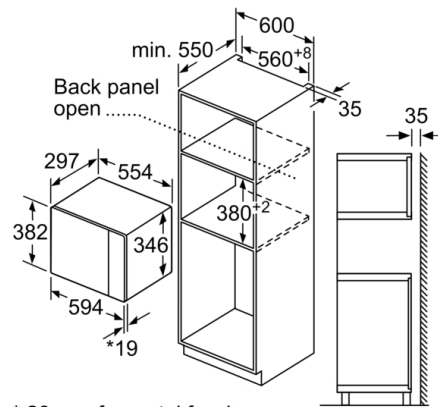

\* 20 mm for metal fascia  
measurements in mm

measurements in mm

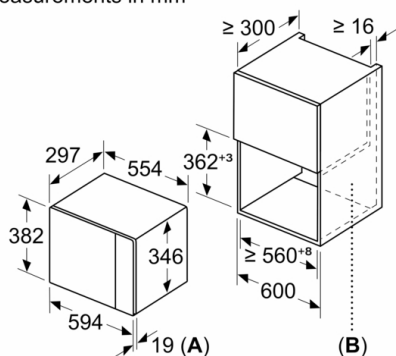

**A:** 20 mm for metal fascia  
**B:** Back panel open