

**Serie | 6, Built-in warming drawer, 60
x 14 cm, Stainless steel
BIC510NS0B**

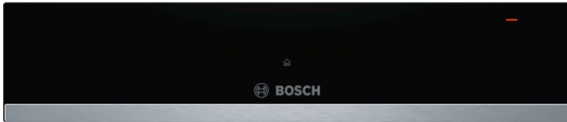

**The multifunction warming drawer for the
14 cm niche: for pre-heating plates and
keeping food warm.**

- **Push-pull mechanism:** easy opening and closing thanks to a clever spring mechanism.

Technical Data

Construction type : Built-in

Color / Material Front : Stainless steel

Maximum number of plates : 14

Maximum number of espresso cups : 64

Dimensions of the packed product (HxWxD) : 210 x 660 x 660
mm

Required niche size for installation (HxWxD) : 140 x 560 x 550
mm

EAN code : 4242005035397

Electrical connection rating : 400 W

Fuse protection : 6 A

Voltage : 220-240 V

Frequency : 60; 50 Hz

Plug type : GB plug

Included accessories

1 x Anti-slip mat



**Serie | 6, Built-in warming drawer, 60 x 14
cm, Stainless steel
BIC510NS0B**

**The multifunction warming drawer for the 14
cm niche: for pre-heating plates and keeping
food warm.**

Design

- Can accommodate up to:
 - 14 plates
 - 64 espresso cups
- Loading up to 15 kg
- Cavity inner surface: stainless steel
- Push-pull opening mechanism

Programmes/functions

- 4 Functions: keeping drinks and food warm, pre-warming of tableware, yeast dough proving, thawing of delicate foods

Accessories

- 1 x Anti-slip mat

Performance/technical information

- Cavity volume: 23 l
- Power cord length 150 cm Cable length
- Total connected load electric: 0.4 KW
- Nominal voltage: 220 - 240 V
- Appliance dimension (hxwxd): 140 mm x 594 mm x 540 mm
- Niche dimension (hxwxd): 140 mm x 560 mm - 568 mm x 550 mm
- Please refer to the dimensions provided in the installation manual

**Serie | 6, Built-in warming drawer, 60 x 14 cm, Stainless steel
BIC510NS0B**

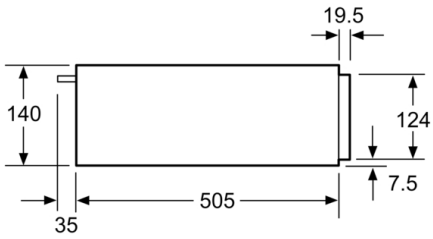

Compact ovens with an appliance height of 455 mm can be installed above a warming drawer. An intermediate floor is not required.

measurements in mm

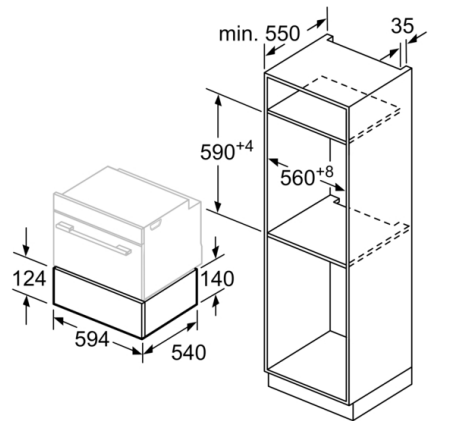

measurements in mm