

**Serie | 8, Built-in warming drawer, 60
x 14 cm, Black
BIC630NB1B**

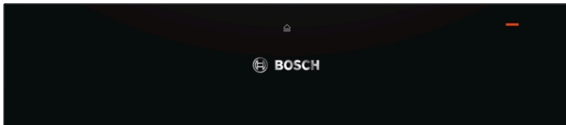

**The multifunctional 14cm warming drawer
pre-heats plates, keeps food warm and even
cooks at low temperatures.**

- **Push-pull mechanism:** easy opening and closing thanks to a clever spring mechanism.
- **Cleaning convenience:** Easy to clean hotplate made of tempered glass.

Technical Data

Construction type : Built-in

Color / Material Front : Black

Maximum number of plates : 12

Maximum number of espresso cups : 64

Dimensions of the packed product (HxWxD) : 210 x 650 x 670
mm

Required niche size for installation (HxWxD) : 140 x 560 x 550
mm

EAN code : 4242002897721

Electrical connection rating : 810 W

Fuse protection : 10 A

Voltage : 220-240 V

Frequency : 60; 50 Hz

Plug type : GB plug



**Serie | 8, Built-in warming drawer, 60 x 14
cm, Black
BIC630NB1B**

**The multifunctional 14cm warming drawer
pre-heats plates, keeps food warm and even
cooks at low temperatures.**

Design

- Push-pull opening mechanism
- Can accommodate up to:
 - 12 plates
 - 64 espresso cups
- Loading up to 25 kg
- Easy to clean toughened glass heating plate

Programmes/functions

- 5 functions: dough proving thawing of delicate foods keeping drinks and food warm pre-warming of crockery gentle cooking
- Temperature control in 4 levels: ca. 30°C - 80°C (glass surface temperature)

Technical information

- Cavity volume: 20 l
- Power cord length 150 cm Cable length
- Total connected load electric: 0.81 KW
- Nominal voltage: 220 - 240 V
- Appliance dimension (hwxwd): 140 mm x 594 mm x 548 mm
- Niche dimension (hwxwd): 140 mm x 560 mm - 568 mm x 550 mm
- Please refer to the dimensions provided in the installation manual

**Serie | 8, Built-in warming drawer, 60 x 14 cm, Black
BIC630NB1B**

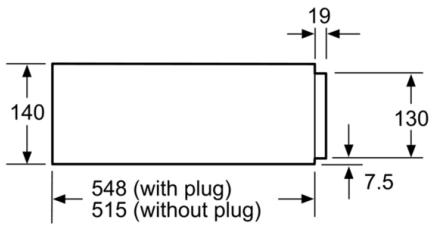

Compact ovens with an appliance height of 455 mm can be installed above a warming drawer. An intermediate floor is not required.

measurements in mm

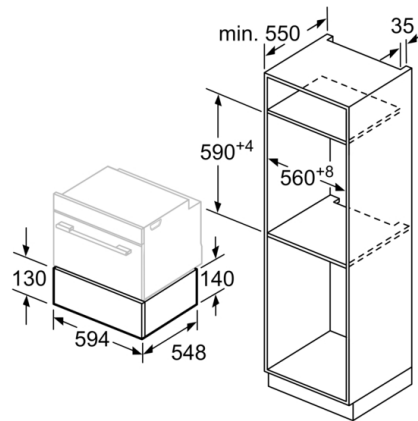

measurements in mm