

N 90, Built-in compact oven with steam function, 60 x 45 cm,
Stainless steel
C18FT56H0B

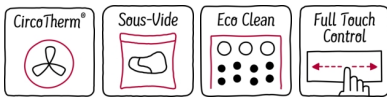

A+



- ✓ Slide® - the rotating handle that sits comfortably in your hand
- ✓ CircoTherm® – Smart hot-air solution that lets you bake on up to four levels.
- ✓ Sous-vide - prepare vacuum-sealed dishes with FullSteam for a new horizon of flavour.
- ✓ Eco Clean with Base Clean - the duo that makes oven cleaning easier
- ✓ Full Touch Control – Simple, precise control by touch on the high-resolution TFT colour display.

Features

Technical Data

Color / Material Front : Stainless steel
 Construction type : Built-in
 Door opening : Drop down
 Required niche size for installation (HxWxD) : 450-455 x 560-568 x 550 mm
 Dimensions of the packed product (HxWxD) : 540 x 660 x 690 mm
 Control Panel Material : Stainless steel
 Door Material : Glass
 Net weight : 34.977 kg
 Approval certificates : CE, VDE
 Length of electrical supply cord : 150 cm
 EAN code : 4242004236412
 Fuse protection : 16 A
 Voltage : 220-240 V
 Frequency : 50; 60 Hz
 Plug type : no plug
 Approval certificates : CE, VDE
 Number of cavities (2010/30/EC) : 1
 Usable volume (of cavity) - NEW (2010/30/EC) : 47 l
 Energy efficiency rating : A+
 Energy consumption per cycle conventional (2010/30/EC) : 0.73 kWh/cycle
 Energy consumption per cycle forced air convection (2010/30/EC) : 0.61 kWh/cycle
 Energy efficiency index (2010/30/EC) : 81.3 %

Optional accessories

Z11AB15A0 : Baking tray, non-stick ceramic coated ,
 Z11SZ00X0 : SeamlessCombination mounting kit ,
 Z11SZ60X0 : SeamlessCombination 45 + 14cm , Z11SZ90X0 :
 SeamlessCombination 60 + 45cm , Z12CB10A0 : Baking tray,
 anthracite enamelled , Z12CM10A0 : Moussaka pan, anthracite
 enamelled , Z12CQ10A0 : Grill tray, anthracite enamelled ,
 Z13CV06S0 : Decor strip , Z13CX62X0 : Vacuum bags 180 x 280
 mm, 100 pcs. , Z13CX64X0 : Vacuum bags 240 x 350 mm, 100
 pcs. , Z13TC10X0 : ComfortFlex Rail (1 level) f. steam , Z13TC14X0 :
 ComfortFlex Rail (1)&racks,45cm f. steam



4 242004 236412

*N 90, Built-in compact oven with steam function,
60 x 45 cm, Stainless steel
C18FT56H0B*

Features

Design

- 5.7" TFT colour and graphics display with FullTouch control
- Cavity inner surface: enamel anthracite
- Drop down door, SoftClose, soft opening
- Touch control
- We recommend you to choose complementary products within N90, in order to assure an optimal design combination of your Built-In appliances.

Features

- HomeConnect ready on WLAN
- Control panel lock
Automatic safety switch off
Residual heat indicator
Start button
Door contact switch
- Temperature proposal
Actual temperature display
Heating up indicator
automatic programmes:
Temperature probe
- Baking and roasting assistant, Automatic programmes
- Water tank empty indicator
- MultiPoint MeatProbe
- LED light, On/off button
- Cooling fan
- Electronic clock timer
- 3 shelf positions

Cleaning

- EcoClean Direct : ceiling, back panel, side liners
- EcoClean programme, Base Clean programme
- Full glass inner door

Programmes/functions

- Compact steam oven with 13 main functions heating methods:
CircoTherm®, CircoTherm® Gentle, Top/bottom heat, Conventional heat Gentle, Circo-roasting, Full surface grill, Centre surface grill, CircoTherm® intensive, Bread baking, Bottom heat, Low temperature cooking, Plate warming, Keep warm
- Additional heating methods with steam: Steaming, Reheat with steam, Dough proving, Defrost
- Additional functions:
De-scaling programme
Drying function
Automatic boiling point detection
- Number of automatic programmes: 30
- Rapid heat

Accessories

- 1 x steam container, punched, size S, 1 x steam container, punched, size XL, 1 x steam container, unpunched, size S, 1 x grid, 1 x universal pan

Performance/technical information

- Energy efficiency rating (acc. EU Nr. 65/2014): A+
Energy consumption per cycle in conventional mode: 0.73 kWh
Energy consumption per cycle in fan-forced convection mode: 0.61 kWh
Number of cavities: Main cavity
Heat source: electrical
Cavity volume: 47 litre
- Temperature range 40 °C - 250 °C
- 1 l Water tank capacity
- Location of water tank: Outside cavity
- Power cord length 150 cm Cable length
- Nominal voltage: 220 - 240 V
- Appliance dimension (hxwx): 455 mm x 596 mm x 548 mm
- Please refer to the dimensions provided in the installation manual

N 90, Built-in compact oven with steam function,
60 x 45 cm, Stainless steel
C18FT56H0B

Dimensioned drawings

Installation with a hob.

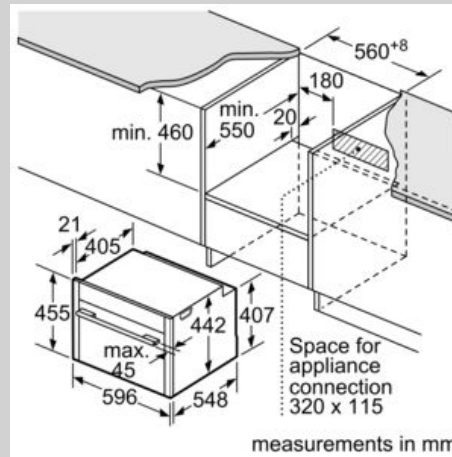
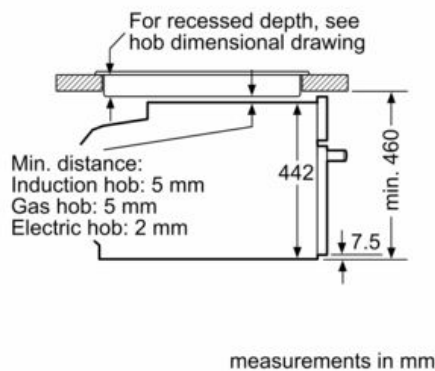

If the compact appliance will be installed underneath a hob, the following worktop thicknesses (including substructure if necessary) must be taken into account.

Hob type	min. worktop thickness	
	fitted	flush
Induction hob	42 mm	43 mm
Full surface Induction hob	52 mm	53 mm
Gas hob	32 mm	43 mm
Electric hob	32 mm	35 mm

