

N 90, Downdraft hood, 90 cm, clear glass black printed  
D95DAP8NOB



COOKING PASSION SINCE 1877



The quiet Downdraft hood with a high extraction rate can be extended from the worktop whenever steam and culinary odours arise.

- ✓ Extendable – Emerges only when needed and sits neatly behind the hob for a clear view in the kitchen
- ✓ Space-saving miracle – Fits neatly behind the hob for more use of the cabinet space underneath
- ✓ Flexible installation – A range of installation options make the most of your cabinet space
- ✓ Quiet operation – Particularly quiet due to its noise-optimised design
- ✓ Integrated lighting – Our downdraft hood with integrated LED lights for clear lighting over your hob

A

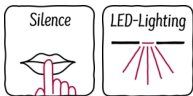

#### Features

##### Technical Data

Typology : Downdraft  
Approval certificates : CE  
Length of electrical supply cord : 150 cm  
Required niche size for installation (HxWxD) : 735mm x 844.0mm x 104mm mm  
Net weight : 35.895 kg  
Type of control : Electronic  
Number of speed settings : 3-stage + 2 intensive  
Maximum output air extraction : 530 m<sup>3</sup>/h  
Boost position output recirculating : 500.0 m<sup>3</sup>/h  
Maximum output recirculating air : 452 m<sup>3</sup>/h  
Boost position air extraction : 750 m<sup>3</sup>/h  
Number of lights (Stck) : 1  
Noise level : 62 dB(A) re 1 pW  
Diameter of air outlet : 150 mm  
Grease filter material : Washable aluminium  
EAN code : 4242004230731  
Connection rating : 317 W  
Fuse protection : 10 A  
Voltage : 220-240 V  
Frequency : 50 Hz  
Plug type : GB plug  
Installation type : Built-in

#### Optional accessories

Z92IDM9X0 Mounting kit remote motor  
Z92IDP9X0  
Z92IDQ9X0



4 242004 230731

N 90, Downdraft hood, 90 cm, clear glass black  
printed  
D95DAP8NOB



COOKING PASSION SINCE 1877

## Features

### Key performance features:

- Energy Efficiency Class: A (at a range of energy efficiency classes from A+++ to D)
- Extraction rate according to EN 61591 ø 15 cm:  
max. Normal use 530 m<sup>3</sup>/h  
Intensive 750 m<sup>3</sup>/h
- Noise max. Normal Level: Noise, max. speed in normal us: 62 dB dB\*

### Features

- Touch control for extractor speeds and light
- 3 power levels and 2 intensive settings
- 1 x 7W LED-module
- Automatic after running (Automatic after running (10 minutes))
- 2 metal grease filter cassettes
- Saturation indicator for metal and charcoal filter

### Design

- Worktop ventilation
- Downdraft for installation in worktops
- Extension height 300 mm
- Rim ventilation
- Electronic controls

### Performance/technical information

- Suitable for ducted extraction and recirculation
- For recirculated extraction recirculating kit (accessory) needed
- In recirculation mode no combination with gas hobs allowed.
- Noise level according to EN 60704-3 and EN 60704-2-13 exhaust air:  
Max. normal use: 62 dB(A) re 1 pW  
Intensive: 67 dB(A) re 1 pW
- Extraction rate in recirculation mode:  
Max. normal use: 452 m<sup>3</sup>/h  
Intensive: 500 m<sup>3</sup>/h
- Noise levels in recirculation mode:  
Max. normal use: 72 dB(A) re 1 pW  
Intensive: 75 dB(A) re 1 pW
- Power rating: 317 W
- Light Intensity: 203 lux
- Colour Temperature: 3500 K
- Electrical cable length 1.5 m
- Blower Efficiency Class: A\*
- Lighting Efficiency Class: A\*
- Grease Filtering Efficiency Class: D\*
- Average Energy Consumption: 54.2 kWh/year\*
- Diameter pipe ø 150 mm (ø 150 mm enclosed)
- Dimensions exhaust air (HxWxD): 735-1035 x 918 x 268 mm
- Dimensions recirculating (HxWxD): 735-1035 x 918 x 268 mm

### Optional accessories

- Recirculating kit Z92IDM9X0
- \* In accordance with the EU-Regulation No 65/2014

N 90, Downdraft hood, 90 cm, clear glass black printed  
D95DAP8NOB

## Dimensioned drawings

## Combination with electric hob

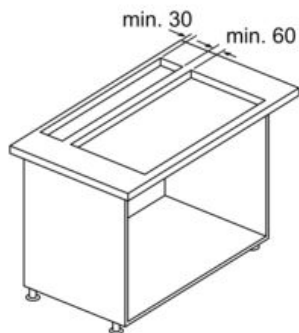

For use with gas hob see drawing "Combination with gas hob".

measurements in mm

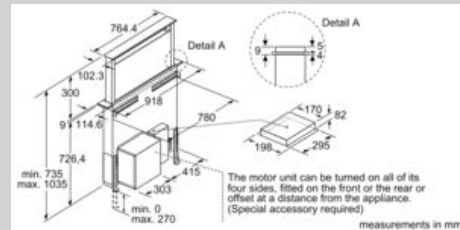

measurements in mm

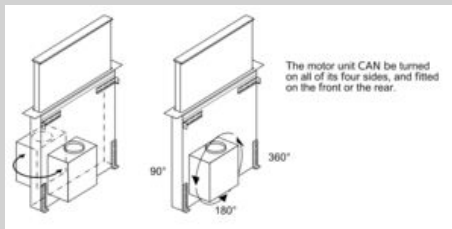

## measurements in mm

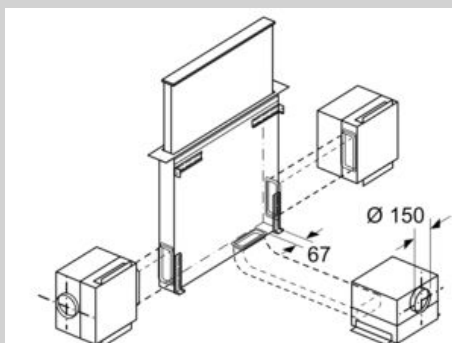
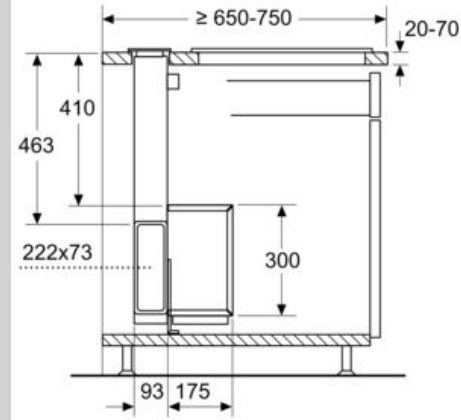

The motor unit can be fitted at a maximum distance of three metres from the appliance. (Special accessory required)

## Combination with gas hob 75 cm

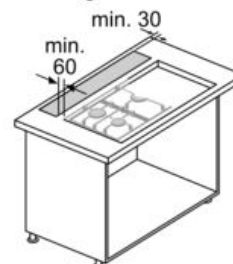

Use with gas hob only possible in air extraction mode.  
Total maximum output: 11.9 kW  
Maximum output of wok 4.2 kW.  
Total maximum output of rear hobs: 4.7 kW

measurements in mm

N 90, Downdraft hood, 90 cm, clear glass black  
 printed  
 D95DAP8NOB

## Dimensioned drawings

Combination with gas hob 90 cm



Use with gas hob only possible  
 in air extraction mode.  
 Total maximum output: 13.7 kW  
 Maximum output of wok 6 kW.  
 Total maximum output of rear hobs: 4.7 kW

measurements in mm

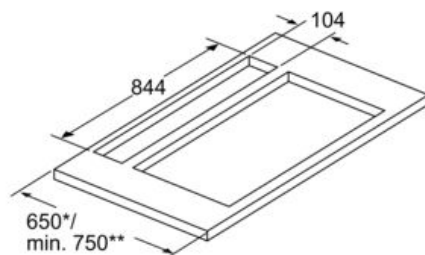

Only install one side of the appliance at  
 least 50 mm from a high-sided unit or a wall.

\* 650 mm depth only in combination with  
 slim hobs.

\*\* min. 750 mm for hobs with 500 mm  
 cut-out depth.

measurements in mm