

N 50, Built-in freezer, 71.2 x 55.8 cm, flat hinge  
G1113FE0



COOKING PASSION SINCE 1877



This built-in freezer helps to defrost faster, comes with a malfunction warning signal and consumes very low energy only.

✓ LowFrost: Reduces frost in the freezer compartment for faster defrosting.

#### Features

##### Technical Data

Energy Efficiency Class : E  
Average annual energy consumption in kilowatt hour per year (kWh/a) : 167 kWh/annum  
Sum of volume of frozen compartments : 72 l  
Airborne acoustical noise emissions : 36 dB(A) re 1 pW  
Airborne acoustical noise emission class : C  
Thermometer freeze section : None  
Light : No  
Product category : Upright freezer  
Construction type : Built-in  
Door panel options : Not possible  
Frost free system : No  
Height of the product : 712 mm  
Width of the appliance : 558 mm  
Depth of the product : 545 mm  
Dimensions of the packed product (HxWxD) : 790 x 640 x 620 mm  
Net weight : 35.626 kg  
Gross weight : 38.0 kg  
Connection rating : 90 W  
Fuse protection : 10 A  
Frequency : 50 Hz  
Approval certificates : CE, VDE  
Length of electrical supply cord : 230 cm  
Door hinge : Right reversible  
Storage Period in Event of Power Failure (h) : 13 h  
Defrost process : manual  
Warning signal / malfunction : visual and audible  
Lockable door : No  
Number of drawers/baskets (Stck) : 3  
Number of freezing flaps (Stck) : 0  
EAN code : 4242004239628  
Brand : Neff  
Product name / Commercial code : G1113FE0  
Product category : Upright freezer



4 242004 239628

*N 50, Built-in freezer, 71.2 x 55.8 cm, flat hinge*  
*G1113FEO*

## Features

### Functions

- Fixed hinge
- Fixed hinge

### Design features

- lowFrost freezer - less ice build up, faster defrosting
- SuperFreeze function with automatic deactivation
- Electronic control (LED chain)
- Freezer malfunction warning signal: optical, acoustical

### Dimension and installation

- Right hinged door, reversible
- Connection value 90 W
- 220 - 240 V
- Dimensions: 71.2 cm H x 55.8 cm W x 54.5 cm D
- Niche Dimensions: 72 cm H x 56 cm W x 55 cm D

### Food freshness system

#### Key features - Freezer section

- Freezing possible in all freezer compartments
- Manual defrost freezer
- 3 freezer drawers
- ice cube tray

#### Included accessories

- KU1213Z0

#### Design features

#### Dimension and installation

- Based on the results of the standard 24-hour test. Actual consumption depends on usage/position of the appliance.

#### Additional features

#### Performance and Consumption

- EU19\_EEK\_D: E
- Total Volume : 72 l
- Net Freezer Volume : 72 l
- Net 4\* compartment volume : 72 l
- Freezing capacity 24h : 4.4 kg
- Annual Energy Consumption: 167 kWh/a
- Climate Class: SN-T
- Noise Level : 36 dB , EU19\_Noise emission class\_D: C
- Temperature rise time : EU19\_Temperature rise time\_D: 13 H

N 50, Built-in freezer, 71.2 x 55.8 cm, flat hinge  
G1113FEO

Dimensioned drawings

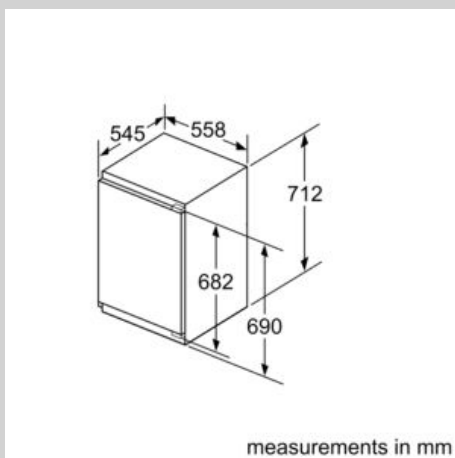
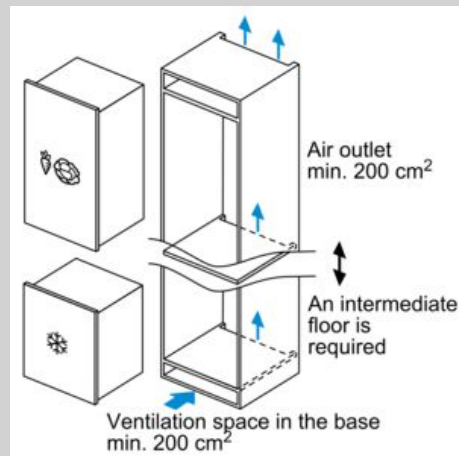
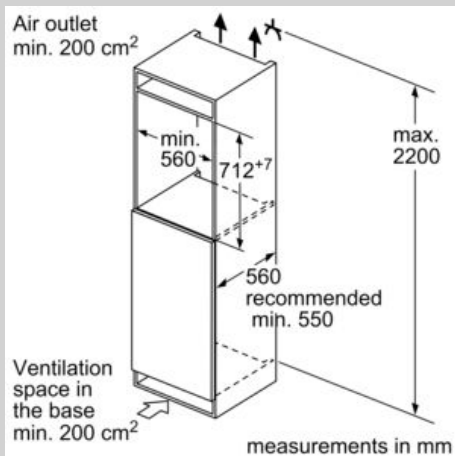

measurements in mm  
Recommended gap dimensions for flat hinges

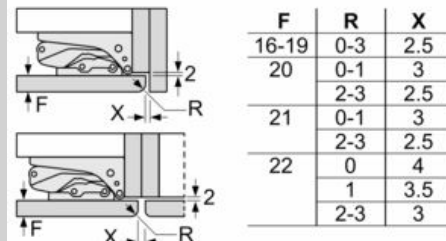

The gap dimensions recommended in the table must be adhered to in order to ensure that appliance doors do not collide with anything when they are opened, and to avoid causing damage to kitchen units.

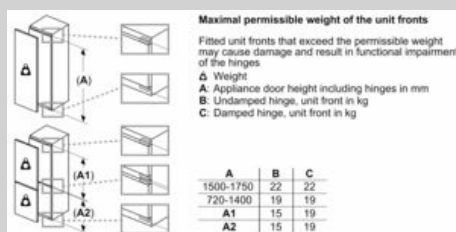
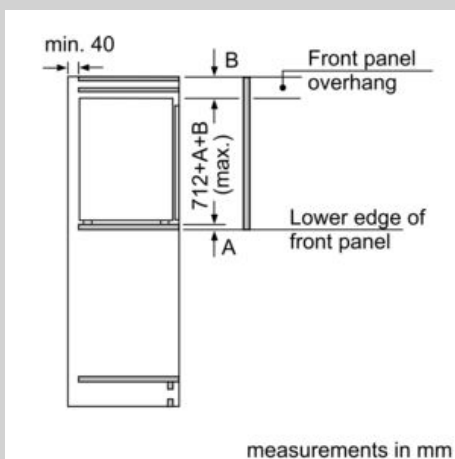

N 50, Built-in freezer, 71.2 x 55.8 cm, flat hinge  
G1113FE0

Dimensioned drawings

