

**Serie | 6, Built-under freezer, 82 x 59.8 cm, flat hinge
GUD15AFF0G**



The freezer with 3 transparent freezer drawers and SuperFreezing: freezes new items placed inside even faster.

- An audible alarm system signals the door is open
- **SuperFreezing:** Protects frozen food from defrosting.

Technical Data

Energy Efficiency Class: F

Average annual energy consumption in kilowatt hour per year (kWh/a): 224 kWh/annum

Sum of volume of frozen compartments: 106 l

Airborne acoustical noise emissions : 38 dB(A) re 1 pW

Airborne acoustical noise emission class: C

Thermometer freeze section: Analog

Light: No

Product category: Upright freezer

Construction type: Built-in

Door panel options: Possible but accessory

Frost free system: No

Height of the product: 820 mm

Width of the appliance: 598 mm

Depth of the product: 548 mm

Dimensions of the packed product (HxWxD): 890 x 620 x 670 mm

Net weight: 36.760 kg

Gross weight: 39.7 kg

Connection rating: 90 W

Fuse protection: 13 A

Frequency: 50 Hz

Approval certificates: CE, VDE

Length of electrical supply cord: 230 cm

Door hinge: Right reversible

Storage Period in Event of Power Failure (h): 10 h

Defrost process: manual

Warning signal / malfunction: visual and audible

Lockable door: No

Number of drawers/baskets (Stck): 3

Number of freezing flaps (Stck): 0

EAN code: 4242005132751

Brand: Bosch

Product name / Commercial code: GUD15AFF0G

Product category: Upright freezer



4 242005 132751

**Serie | 6, Built-under freezer, 82 x 59.8 cm,
flat hinge
GUD15AFF0G**

**The freezer with 3 transparent freezer
drawers and SuperFreezing: freezes new
items placed inside even faster.**

Included accessories

- KFZ10AX0, KUZ20SX0

Functions

- Combined to Fridge/Freezer combination

Design features

- Fixed hinge
- Mechanical control
- Freezer malfunction warning signal: optical and acoustical warning system
- SuperFreezing function with automatic deactivation

Food freshness system

- 3 freezer drawers

Dimension and installation

- Dimensions: 82 cm H x 59.8 cm W x 54.8 cm D
- Niche Dimensions: 82 cm H x 60 cm W x 55 cm D

Key features - Fridge section

- Right hinged door, door reversible
- Connection value 90 W
- 220 - 240 V

Key features - Freezer section

- GUD15AFF0G

Country Specific Options

- Based on the results of the standard 24-hour test. Actual consumption depends on usage/position of the appliance.

Design features

Dimension and installation

Performance and Consumption

- EU19_EEK_D: F
- Total Volume : 106 l
- Net Freezer Volume : 106 l
- Freezing capacity 24h : 7.4 kg
- Annual Energy Consumption: 224 kWh/a
- Climate Class: SN-T
- Noise Level : 38 dB , EU19_Noise emission class_D: C
- Temperature rise time : EU19_Temperature rise time_D: 10 H

**Serie | 6, Built-under freezer, 82 x 59.8 cm,
flat hinge
GUD15AFF0G**

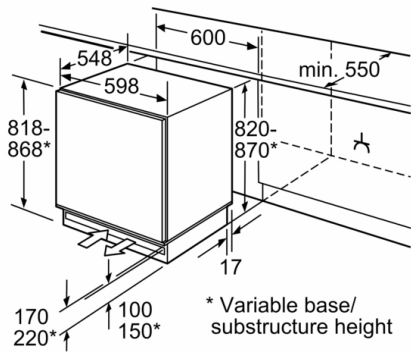

Space for electrical connection next to the appliance on the left or right-hand side.
Ventilation space in the base.

measurements in mm

measurements in mm
Recommended gap dimensions for flat hinges

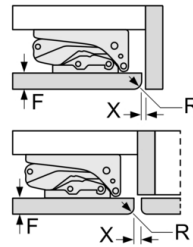

F	R	X
16-19	0-3	2.5
20	0-1	3
	2-3	2.5
21	0-1	3
	2-3	2.5
22	0	4
	1	3.5
	2-3	3

The gap dimensions recommended in the table must be adhered to in order to ensure that appliance doors do not collide with anything when they are opened, and to avoid causing damage to kitchen units.

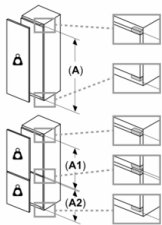

Maximal permissible weight of the unit fronts

Fitted unit fronts that exceed the permissible weight may cause damage and result in functional impairment of the hinges

- Δ Weight
- A: Appliance door height including hinges in mm
- B: Undamped hinge, unit front in kg
- C: Damped hinge, unit front in kg

A	B	C
1500-1750	22	22
720-1400	19	19
A1	15	19
A2	15	19