

N 70, Built-in fridge, 122.5 x 56 cm, flat hinge
KI1413FF0G



COOKING PASSION SINCE 1877



This built-in refrigerator keeps fruit and vegetables fresher for longer.

- ✓ Fresh Safe 2 <0°C> – Ideal storage for fruit and vegetables, fish and meat.
- ✓ Bottle Flex Shelf – The bottle holder and shelf in one.
- ✓ Easy Access Shelf – Slides out to give you better access to fridge contents.
- ✓ VarioShelf: The glass shelf can be divided and one half pushed beneath the other, for flexible interior configurations.
- ✓ Adjustable Glass Shelves – Height adjustable shelves create the space you need for inspiring dishes in your fridge

Features

Technical Data

Energy Efficiency Class : F
 Average annual energy consumption in kilowatt hour per year (kWh/a) : 123 kWh/annum
 Sum of volume of frozen compartments : 0 l
 Sum of volume of chill compartments : 211 l
 Airborne acoustical noise emissions : 33 dB(A) re 1 pW
 Airborne acoustical noise emission class : B
 Construction type : Built-in
 Door panel options : Possible but accessory
 Height : 1221 mm
 Width of the appliance : 558 mm
 Depth of the product : 545 mm
 Required niche size for installation (HxWxD) : 1225.0 x 560 x 550 mm
 Net weight : 48.591 kg
 Connection rating : 90 W
 Fuse protection : 13 A
 Door hinge : Right reversible
 Voltage : 220-240 V
 Frequency : 50 Hz
 Approval certificates : CE, VDE
 Length of electrical supply cord : 230 cm
 Number of compressors : 1
 Number of independent cooling systems : 1
 Interior ventilator : No
 Reversible Door Hinge : Yes
 Number of Adjustable Shelves in fridge compartment (Stck) : 4
 Shelves for Bottles : No
 EAN code : 4242004264378
 Brand : Neff
 Product name / Commercial code : KI1413FF0G
 Product category : Refrigerator
 Frost free system : No
 Installation type : Full-integrated

Optional accessories

Z10020 Bottle Rack



4 242004 264378

N 70, Built-in fridge, 122.5 x 56 cm, flat hinge
KI1413FF0G



COOKING PASSION SINCE 1877

Features

- Easy Installation

Performance and Consumption

- EU19_EEK_D: F
- Total Volume : 211 l
- Net Fridge Volume : 211 l
- Net Freezer Volume : 0 l
- Annual Energy Consumption: 123 kWh/a
- Climate Class: SN-ST
- EU19_Fast freezer facility_D
- Noise Level : 33 dB , EU19_Noise emission class_D: B

Functions

- Bright interior LED fridge light

Design features

- Touchcontrol- Electronic - LED Electronic control
- FreshSense - constant temperature by intelligent sensor technology - Constant temperature control by intelligent sensor technology
- Automatic defrost fridge
- Super Cooling: automatic deactivation
- Acoustic door open warning indicator

Design features

- 6 safety glass shelves (4 height adjustable)
- 4 door trays, including 1x dairy compartment
- bottle holder in door tray

Freshness System

- 1 FreshSafe 2 drawer; High humidity retains nutrients up to twice as long

Dimension and installation

- Dimensions: 122.1 cm H x 55.8 cm W x 54.5 cm D
- Niche Dimensions: 122.5 cm H x 56 cm W x 55 cm D

Key features - Fridge section

- Right hinged door, reversible
- Connection value 90 W
- 220 - 240 V

Key features - Freezer section

- KI1413FF0G

Included accessories

- KF1413S0, KF1413Z0, KSGG0MZ0, Z10020

Country Specific Options

- Based on the results of the standard 24-hour test. Actual consumption depends on usage/position of the appliance.

Design features

Dimension and installation

Additional features

- 3 egg trays
- Easy access shelf - easy access and everything in sight
- Vario shelf - useful storage when required
- BottleFlex Shelf

N 70, Built-in fridge, 122.5 x 56 cm, flat hinge
K11413FF0G

Dimensioned drawings

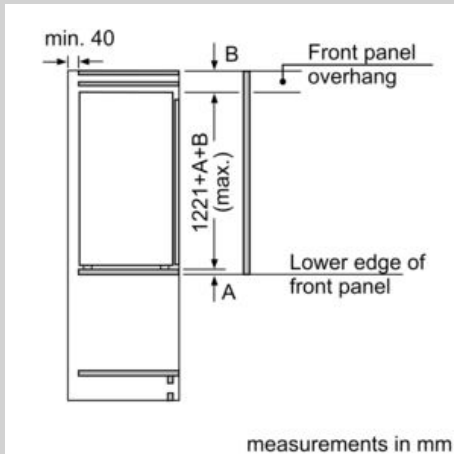

measurements in mm
Recommended gap dimensions for flat hinges

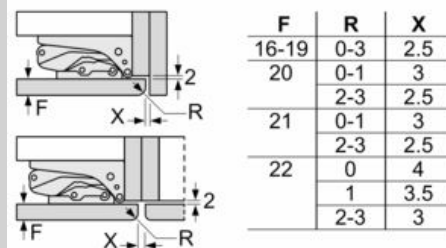

The gap dimensions recommended in the table must be adhered to in order to ensure that appliance doors do not collide with anything when they are opened, and to avoid causing damage to kitchen units.

