

**Serie | 6, Heat pump tumble dryer, 8 kg  
WTR88T81GB**



**A+++**



**Optional accessories**

WTZ1110 : Condenser drainage kit  
WTZ27400 : Stacking kit with pull-out shelf  
WTZ27410 : Stacking kit

**The dryer for high drying performance with low energy consumption of A+++.**

- **EasyClean with A+++:** dries extremely efficiently. Condenser filter can be easily maintained.
- **AutoDry:** gently dries laundry to exactly the degree of dryness you want.
- **AntiVibration Design:** extremely stable and especially quiet thanks to special vibration protection.
- **Sensitive Drying system:** soft, even drying thanks to the unique drum structure.
- **Big LED Display:** easy operation and extra functions available.

**Technical Data**

Construction type : Free-standing  
Removable work top : No  
Door hinge : Right  
Length of electrical supply cord : 145.0 cm  
Height of removable worktop : 842 mm  
Dimensions of the product : 842 x 598 x 599 mm  
Net weight : 53.232 kg  
Fluorinated greenhouse gases : No  
Type of refrigerant : R290  
Hermetically sealed equipment : Yes  
Quantity of fluorinated gases : 0.149 kg  
The quantity expressed in CO2 equivalent : 0.000 t  
EAN code : 4242005156849  
Connection rating : 1000 W  
Fuse protection : 10 A  
Voltage : 220-240 V  
Frequency : 50 Hz  
Approval certificates : CE, E17D UKCA marking, VDE  
Capacity cotton - NEW (2010/30/EC) : 8.0 kg  
Energy efficiency rating : A+++  
Energy consumption electric dryer, full load - NEW (2010/30/EC) : 1.40 kWh  
Standard cotton programme time at full load : 159 min  
Energy consumption electric dryer, partial load - NEW (2010/30/EC) : 0.83 kWh  
Standard cotton programme time at partial load : 100 min  
Weighted annual energy consumption, electric dryer - NEW (2010/30/EC) : 176.0 kWh/annum  
Weighted programme time : 125 min  
Average condensation efficiency full load (%) : 90 %  
Average condensation efficiency partial load (%) : 91 %  
Weighted condensation efficiency (%) : 91 %



## Serie | 6, Heat pump tumble dryer, 8 kg WTR88T81GB

### The dryer for high drying performance with low energy consumption of A+++.

#### Performance

- Energy Efficiency Class: A+++ at a range of energy efficiency classes from A+++ to D
- Capacity: 8 kg
- Energy consumption 176.0 kWh per year, based on 160 drying cycles of the standard cotton programme at full and partial load, and the consumption of the low-power modes. Actual energy consumption per cycle will depend on how the appliance is used
- Energy consumption of the standard cotton programme at full load 1.4 kWh and energy consumption of the standard cotton programme at half load 0.83 kWh
- The programme Cotton cupboard dry used at full and partial load is the standard drying programme to which the information in the label and the fiche relates, this programme is suitable for drying normal wet cotton laundry and is the most efficient programme in terms of energy consumption for cotton.
- Programme time of the standard cotton programme at full load 159 min and programme time of the standard cotton programme at partial load 100 min.
- Weighted programme time of the standard cotton programme at full and partial load: 125 min.
- Condensation efficiency class A on a scale from G (least efficient) to A (most efficient).
- Average condensation efficiency of the standard cotton programme at full load 90 % and average condensation efficiency of the standard cotton programme at partial load 91 %.
- Weighted condensation efficiency for the standard cotton programme at full and partial load: 91 %.
- Power consumption in off-mode 0.1 W and in left-on mode 0.75 W
- Duration of left-on mode: 30 min
- Noise level: 64 dB (A) re 1 pW

#### Programmes/functions

- Fully electronic control dial for sensor programmes and timed programmes
- Standard programmes: cotton, easy care
- Special programmes: Shirts/blouses, Delicates, Towels, Mixed Load, Super Quick 40, Sportswear, Woollens, Timed programme cold, Timed programme warm
- Touch control buttons: end Time Delay, Reduced ironing, Drying length, Low heat, Buzzer, Start / Reload / Pause, fine-tuning for drying level, 24 h end Time Delay

#### Key features

- EasyClean filter
- Heat pump technology with climate friendly cooling agent
- Sensitive drying: large stainless steel drum with textile care and revolution drying system
- AntiVibration design: for greater stability and quietness

#### Additional features

- Large LED display for remaining time and 24 hours time delay, programme progress indication and special functions
- Soft dial
- Container for condensed water
- Anti crease cycle 60 minutes at the end of the programme
- Drum interior light
- Child lock
- Buzzer to indicate the end of cycle
- Metal door catch
- Door hinge: right-hand

#### Technical Information

- Dimensions (H x W): 84.2 cm x 59.8 cm
- Appliance depth: 59.9 cm
- Appliance depth with open door: 108.6 cm
- slide-under installation
- Glass door,, silver-white

**Serie | 6, Heat pump tumble dryer, 8 kg  
WTR88T81GB**

measurements in mm

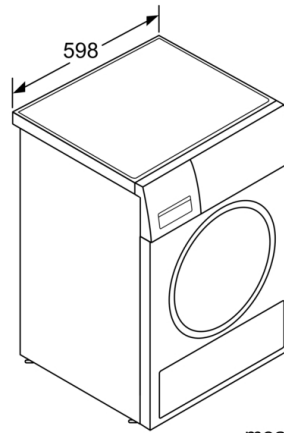
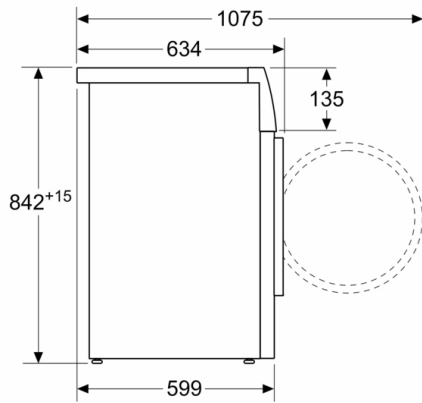

measurements in mm